

Forklift AMR

F150



Features

- Customizable modules for control over stacking height and load requirements;
- Self-adaptive pallet recognition;
- Large-angle design for obstacle avoidance to eliminate interruptions in daily work;
- Stable performance that ensures the system lasts through multiple usages;
- Supports elevating the fork and sinking during marching for improved efficiency.

Dimensions (mm)

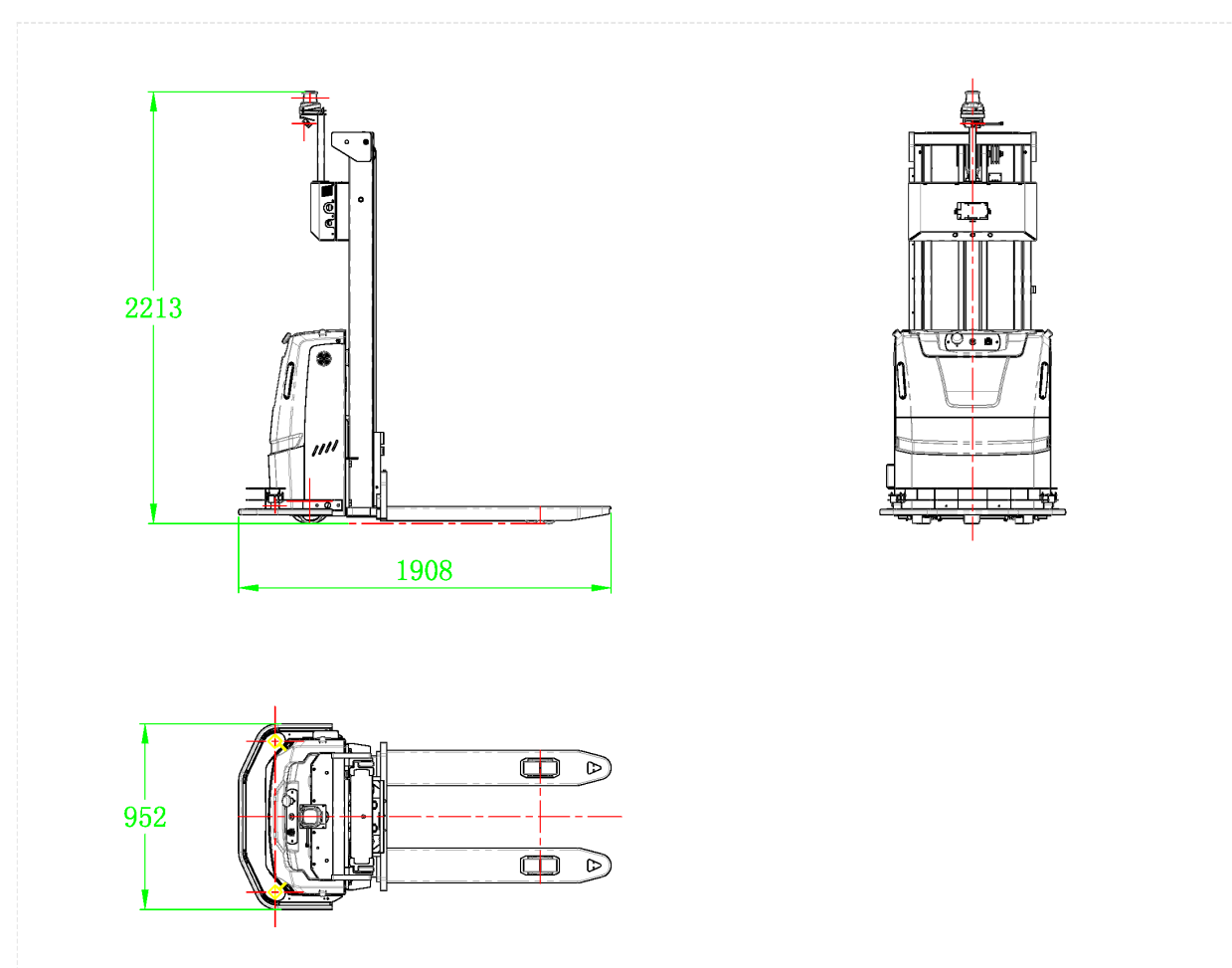

Specification

Model		F150
Basic	Product Dimensions	2,170 mm × 930 mm × 2,250 mm (85.43" × 36.61" × 88.58")
	Load Center	600 mm (23.62")
	Lifting Height	3,000 mm (118.11")
	Min. Passage Width	2,600 mm (102.36")
	Net Weight	750 kg (1,653.47 lb)
	Load Capacity	1,500 kg (3,306.93 lb)
	LCD Display	Yes
	Min. Fork Clearance Height	85 mm (3.35")
	Navigation	Laser SLAM
	Communication Mode	Wi-Fi
	Drive	Steering wheel
Performance	Rated Operating Speed	1 m/s (3.28 ft/s)
	Stop Position Accuracy	±10 mm (0.39")
	Climbing Ability	0.1
Obstacle Avoidance	Obstacle Avoidance Method	Laser+visual+photodiode+anti-collision
	Anti-collision Bar Detection	Yes
	Stop Button	Yes
	Sound and Light Alarm	Yes
Battery	Battery Capacity	24 V/100 A·h
	Operating Time	8 h
	Charging Mode	Manual; auto
	Battery Life	1500 times
Environment	Operating Temperature	0 °C to +50 °C (+32 °F to +122 °F)
	Operating Humidity	5%–95%